

# HIGH VOLUME INDUSTRIAL AERATOR SPECIFICATIONS

**MODEL:** The aerator shall be a floating, surface spray aerator with a “boil” like spray pattern. Spray dimensions are: \_\_\_\_\_ feet ( \_\_\_\_\_ m) in height, and \_\_\_\_\_ feet ( \_\_\_\_\_ m) in diameter.

**PUMPING CAPACITIES:** The primary pumping rate of the unit is \_\_\_\_\_ GPM ( \_\_\_\_\_ m<sup>3</sup>/hr) and the secondary or induced circulation rate is \_\_\_\_\_ GPM ( \_\_\_\_\_ m<sup>3</sup>/hr).

**FLOAT:** The float shall be made of seamless, one-piece high-density polyethylene plastic, filled with high density closed cell polyurethane foam. The float shall be capable of providing full floatation if the shell is punctured or cracked. Metal floats or those with an internal void for additional ballast are not acceptable.

**IMPELLER:** The impeller shall be dynamically balanced and constructed of type 304 stainless steel. It shall be welded to a type 304 stainless steel sleeve with integral key. The welded assembly shall be connected to the motor by a type 304 stainless steel bolt, extending through the impeller and sleeve. Flexible shaft couplings are not acceptable.

**MOTOR:** The motor shall be a \_\_\_\_\_ HP, \_\_\_\_\_ volt, \_\_\_\_\_ phase, \_\_\_\_\_ HZ oil-cooled, submersible motor operating at 1725 RPM or 50 Hz operates at 1425 RPM. The service factor shall be 1.15. The motor shall operate in a reservoir of Otterbine oil for continuous lubrication of bearings and for efficient transfer of heat through the motor housing wall. Top mounted motors and water-lubricated motors are not acceptable. The rotor shall be dynamically balanced. The winding (stator) wires shall be covered with class F rated insulation designed for complete immersion in oil. The motor shall be attached to a Valox thermoplastic molded upper plate. This plate will house the bearings and upper motor seals (internal and external). The motor shall be protected against oil and water leakage by a combination of rotary seals, stationary seals, and molded rubber “O” rings.

**MECHANICAL SEAL:** The seal shall be a Viton mechanical spring seal with a 304 st/st spring and ceramic facing. The seal shall be rated for 200 degrees Celcius.

**MOTOR HOUSING:** The external motor housing shall be a canister formed from deep drawn 316 stainless steel. The top plate shall be constructed of Valox thermoplastic. A Valox boss will provide support and protection for the male electrical connector.

**SUPPORT FRAME:** The support frame for the aerator shall be constructed of type 304 stainless steel tube welded with a type 308 stainless steel weld.

**FASTENERS:** All fasteners are to be type 304 or 316 stainless steel.

**ELECTRICAL CONNECTORS:** The electrical connectors shall consist of a receptacle and a plug constructed of non-conductive polymers. The system shall create a vacuum seal when connected and have a threaded nut system as a backup. The plug shall have a keyway and be threaded into the top plate. The connector system shall be ETL, UL and CSA approved.

**UNDERWATER POWER CABLE:** The power cables shall be type SOOW specifically designed for underwater use. The conductors shall be flexible, stranded bare copper 12, 10 or 8 gauge, triple insulated to resist moisture, wicking, cracking, and softening. The outer jacket of the cable shall be a black CPE material. All underwater connections shall be vulcanized. Power cable shall be able to be furnished in unspliced lengths up to one thousand feet (305m) if necessary.



[www.otterbine.com/highvolume](http://www.otterbine.com/highvolume)

 CADdetails

**POWER CONTROL CENTER:** The electrical components shall be mounted in a NEMA 4X rated enclosure with an externally mounted disconnect switch, and a MANUAL - OFF - AUTO selector switch. The electrical system for all units (115, 208-230, 380-415 & 460V) shall include a non-reversing 600V rated Manual Motor Controller (MMC) with thermal overload and short circuit trip and 24hr timer. 115, 208-230 volt, single and three phase units shall include GFCI (Ground Fault Circuit Interrupter) protection. To operate the GFCI and control circuit on 208-230 volt systems a neutral must be present or an optional control transformer may be supplied. The electrical system shall include a lightning arrester, rated for a maximum of 60,000 amperes discharge.

**TESTING:** A. Safety - The aerator system shall be tested and approved as a unit. Separate component testing not allowed. Unit must be tested by ETL, ETL-C, CE, UL or other accredited testing facilities. B. Performance - Unit must have independent performance testing provided by the University of Minnesota.

**WARRANTY:** The warranty shall be three years.

**ACCEPTABLE MANUFACTURER:** This unit shall be an OTTERBINE High Volume Industrial Aerator manufactured by OTTERBINE BAREBO, INC., 3840 MAIN ROAD EAST, EMMAUS, PA 18049 U.S.A. PH: (610) 965-6018. WEB: [www.otterbine.com](http://www.otterbine.com)

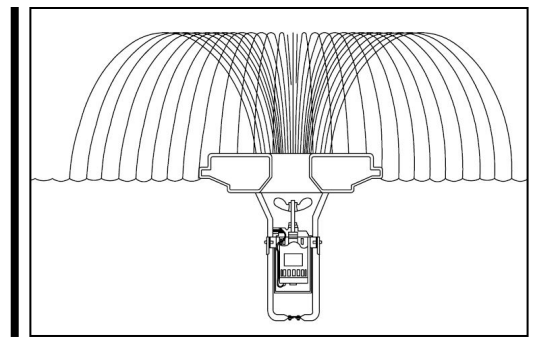

CAD Detail: High Volume

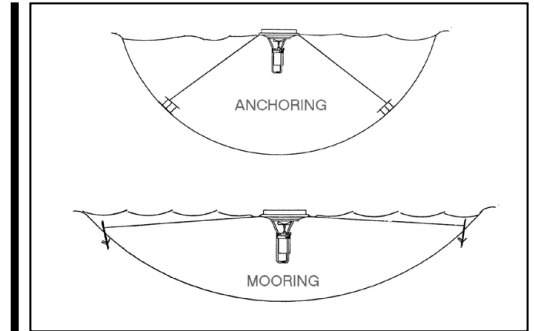

Installation Methods

## MODEL: HIGH VOLUME INDUSTRIAL AERATOR

Motor	HP	Spray Height ft (m)	Spray Diameter ft (m)	Pumping Rate* GPM (m <sup>3</sup> /hr)	Electrical Rating	Running Amps	Maximum Cable Gauge/Length (†Additional cable options may be available)			Shipping Weight**
							12AWG/4mm <sup>2</sup>	10AWG/6mm <sup>2</sup>	8AWG/10mm <sup>2</sup>	
1725RPM @ 60Hz	1	1.5ft	4ft	920 GPM	115V 1Ph	13.4	<del>12AWG/4mm<sup>2</sup></del>	150ft	250ft	200lbs
					208/230V 1Ph	6.8	375/425ft	600/675ft	950/1000ft	
	2	2ft	7ft	1,525 GPM	208/230V 1Ph†	11.9	200/225ft	325/375ft	525/600ft	200lbs
					208/230V 1Ph†	13.5	<del>12AWG/4mm<sup>2</sup></del>	275/325ft	450/500ft	
					208/230V 3Ph	8.5	350/375FT	550/625ft	900/1000ft	
	3	3ft	9ft	2,100 GPM	460V 3Ph†	4.2	1000ft	<del>10AWG/6mm<sup>2</sup></del>	<del>8AWG/10mm<sup>2</sup></del>	205lbs
208/230V 3Ph					14.4	200/225ft	325/350ft	500/575ft		
5	4.5	11	3,000 GPM	208/230V 3Ph	14.4	200/225ft	325/350ft	500/575ft	210lbs	
				460V 3Ph†	7.5	900ft	1000ft	<del>10AWG/6mm<sup>2</sup></del>		
1425 RPM @ 50Hz	1	.5m	1.2m	198.5 m <sup>3</sup> /hr	220V 1Ph	8	130m	206m	305m	91kg
	2	.6m	2.3m	329 m <sup>3</sup> /hr	220V 1Ph	12	69m	114m	183m	91kg
	3	.9m	2.6m	453.1 m <sup>3</sup> /hr	220V 1Ph	14	<del>12AWG/4mm<sup>2</sup></del>	99m	152m	93kg
					380/415V 3Ph†	4.2	305m	<del>10AWG/6mm<sup>2</sup></del>	<del>8AWG/10mm<sup>2</sup></del>	
	5	1.1m	3.5m	647.2 m <sup>3</sup> /hr	380/415V 3Ph†	7.2	274m	305m	<del>10AWG/6mm<sup>2</sup></del>	95kg

\*Induced Circulation is 10X the Pumping Rate. \*\* Shipping weights are estimates and include unit, power control center and 50ft (15m) of cable. (50Hz units do not receive power control center.) Minimum operating depth is 30in (75cm). 415V and 575V units available upon request. *Spray performance and pumping rates are approximate and may vary due to voltage, elevation and relative humidity.* Specifications are subject to change.